

# EX-TRABEAM®

SMART CUTTING. BEST RESULTS.

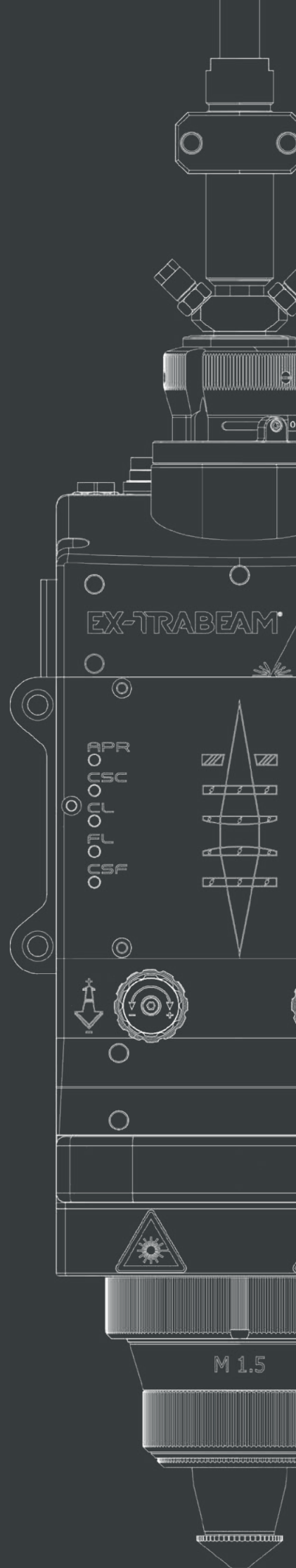



**SMART CUTTING.  
BEST RESULTS.**

# THE CUTTING COMPANY®

THERMACUT® is one of the world's leading specialists for reliable, powerful and cost-effective plasma, oxy-fuel and laser cutting solutions.

One of its main areas of expertise is optimizing original consumables, torches and tube packages to make them more durable, reliable and cost-effective. The company boasts a unique product portfolio in terms of both its width and depth.

In its development and production activities, THERMACUT® makes the most of more than 30 years of experience as a reliable partner for high-quality consumables and powerful system solutions.

Its intelligently networked EX-TRABEAM® laser cutting systems with an innovative service concept are a prime example of such solutions.



## EX-TRABEAM® LASER CUTTING HEAD

### TABLE OF CONTENTS

#### SHORT INTRODUCTION

THERMACUT® THE CUTTING COMPANY	4
EX-TRABEAM® series	6

#### BENEFIT OF THE SERIES

NEW TECHNOLOGY INTELLIGENCE IN THE CUTTING HEAD	7
ETHERCAT INTERFACE, ADVANTAGES FOR INTEGRATORS	8
STRONG CUTTING PERFORMANCE, MAXIMUM FLEXIBILITY	9
INTERFACE AND SYSTEM INTEGRATION, INDUSTRY 4.0	10
SERVICEABILITY AND COST-EFFECTIVENESS	11

#### OVERVIEW OF MODELS

EX-TRABEAM® ECO	12 - 14
EX-TRABEAM® HP	14 - 15
EX-TRABEAM® XP	16 - 17
EX-TRABEAM® ZOOM	18 - 19

# SMART CUTTING. BEST RESULTS.

## THE NEW EX-TRABEAM® SERIES.

This range of laser cutting heads has been completely redeveloped. One of the changes implemented was to embed the entire device electronics into the cutting head. This provides both technical and economic advantages and makes the heads the ideal components for cutting systems that meet the requirements of smart factories and Industry 4.0.

The cutting heads in the EX-TRABEAM® series are available as four different models. They offer integrators new scope for creativity in terms of technology and design and impress users with their outstanding cutting results.

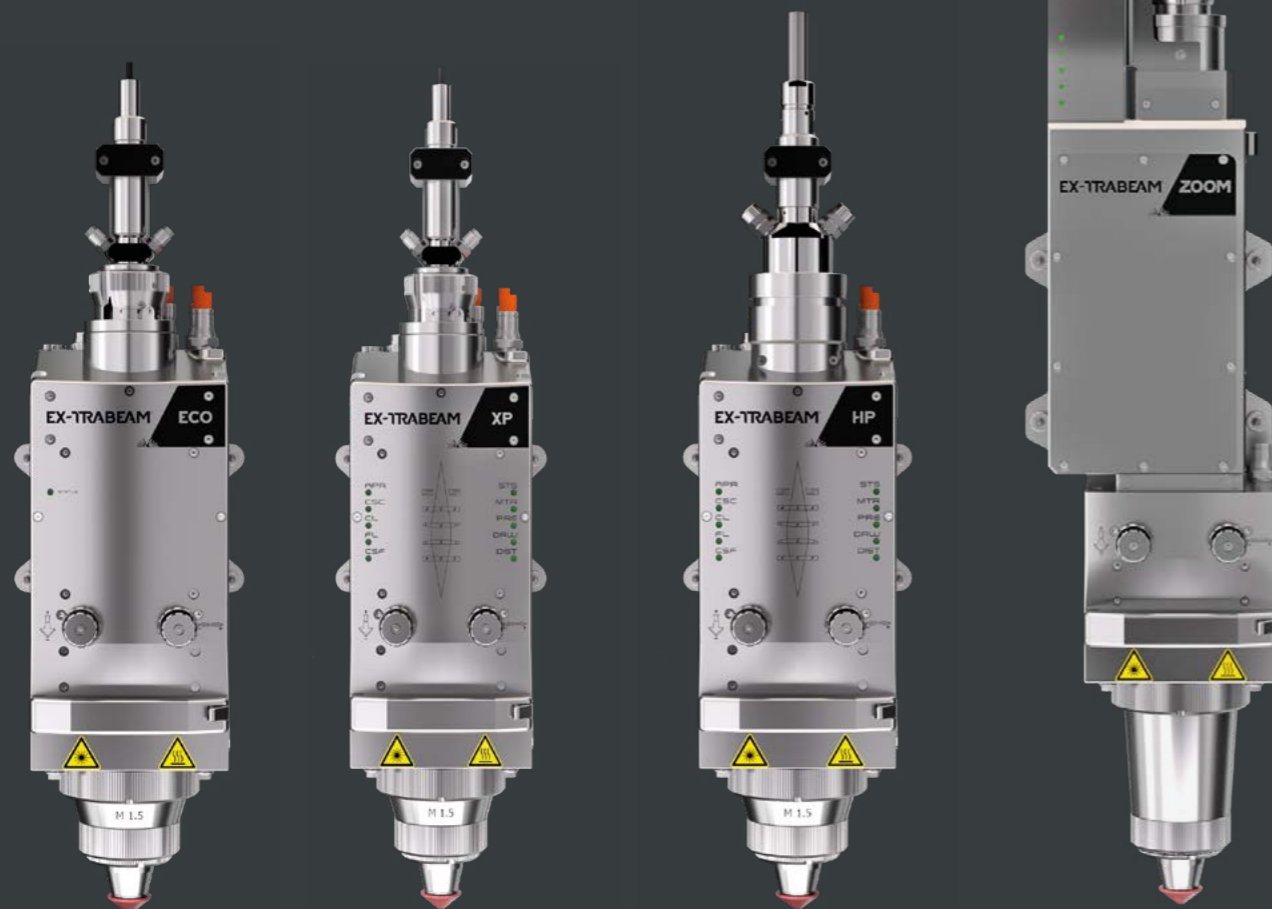

## THE INTELLIGENT FIBER LASER CUTTING HEADS IN THE NEW EX-TRABEAM® SERIES.

**Offers reliable, future-proof and cost-effective cutting technology  
for Industrial applications up to 20 kW.**

The products boast an innovative device concept in which the entire device intelligence is embedded into the cutting head. The laser cutting heads offer maximum operational reliability and work with the laser sources of all established manufacturers.

The cutting heads in the EX-TRABEAM® series are available as four different models. They offer integrators new scope for creativity in terms of technology and design and impress users with their outstanding cutting results.

## AN INTELLIGENT CUTTING HEAD STRUCTURE

The intelligent fiber laser cutting heads in the new EX-TRABEAM® series offer reliable, future-proof and cost-effective cutting technology for industrial applications up to 20 kW.

## ADVANTAGES FOR INTEGRATORS

- ▶ More space on the head
- ▶ Easier system integration
- ▶ Flexible communication
- ▶ Reduced service times/costs
- ▶ Better cutting results
- ▶ Updatable technology



## ETHERCAT INTERFACE

A high-performance real-time communication interface for:

- ▶ Control
- ▶ Systems communication
- ▶ Monitoring
- ▶ Data logging



## CONTROL SYSTEM

An embedded microprocessor for controlling all functions and monitoring sensors:

- ▶ Cutting process monitoring incl. height sensing
- ▶ Monitoring the optical system



## POWERFUL AND HIGHLY FLEXIBLE

With their excellent cutting performance and outstanding cutting quality, the cutting heads in the EX-TRABEAM® series meets all of the typical demands of manufacturing companies. What's more, they also offer a multitude of other clear competitive advantages.

## STRONG CUTTING PERFORMANCE

The innovative design of the EX-TRABEAM® cutting heads is tailored to achieve maximum performance and optimum cutting results.

- ▶ The optimized gas flow management automatically compensates for fluctuations in the gas supply.
- ▶ The optical system is perfectly designed to complement the high laser power.
- ▶ Motorized collimation for automated focus position adjustment up to 45 mm.
- ▶ The specially developed cooling system reliably protects all critical components.

## MAXIMUM FLEXIBILITY

With its four different models, the EX-TRABEAM® series ticks all the boxes when it comes to providing needs-based laser cutting technology for a wide range of areas of application from one single source.

- ▶ Three models with motorized focus control are available with laser powers of 1 to 20 kW.
- ▶ The flexible Zoom model has a variable focus ranging from 0.9 to 4.0 M.
- ▶ Ideal for the precise cutting of thin and thick sheet metal and other materials.
- ▶ Available for all laser sources in the market, ring mode laser, HLC-16 connector, laser power up to 20 kW.
- ▶ Piercing sensors integrated as standard for additional applications.



## INTERFACES AND SYSTEM INTEGRATION

The EX-TRABEAM® series is extremely future-proof thanks to its embedded control system with an EtherCAT interface. The intelligent components ensure easy system integration, comprehensive monitoring options and Industry 4.0-ready data handling.

### EASY SYSTEM INTEGRATION

- ▶ A processor for the control of all functions embedded into the cutting head
- ▶ No additional cables or control boxes required
- ▶ Fewer components, fewer sources of disturbance and easier handling.
- ▶ Platform construction with many common parts and universal control.

### CONTROL AND DATA EXCHANGE VIA ETHERCAT

Real-time cutting head monitoring • Prevents crashes and plant shutdowns • Quick reaction times in case of disturbances • Significantly higher operational reliability

### CUTTING PROCESS MONITORING

- ▶ Height sensing with a reaction time of 1 msec
- ▶ Process gas pressure
- ▶ Process gas humidity
- ▶ Nozzle touch
- ▶ Nozzle loss
- ▶ Process gas pressure
- ▶ Process gas humidity
- ▶ Body touch
- ▶ Piercing process

### OPTICAL MONITORING

- ▶ Laser light cable exit
- ▶ Protective glass before the collimation system
- ▶ Collimation lens system
- ▶ Focusing lens system
- ▶ Protective glass for the process
- ▶ Optical cavity



## SERVICEABILITY AND COST-EFFECTIVENESS

The structural design of the EX-TRABEAM® cutting heads facilitates a completely new service concept. This saves time and money and offers clear advantages for integrators and their customers.



### QUICKER AND MORE AFFORDABLE REPLACEMENT OF OPTICAL ELEMENTS

- ▶ Defect optical elements can be replaced directly on the machine without removing the cutting head
- ▶ The laser head does not need to be sent in
- ▶ No optical recalibration required
- ▶ Reduced stock of replacement heads possible
- ▶ No unnecessary waiting times for customers

### SIMPLE REPAIR OF THE NOZZLE MODULE

- ▶ Nozzle module with a 3-part modular structure
- ▶ Cost-saving replacement in the case of crashes or defects

### PRACTICAL REMOTE MAINTENANCE

- ▶ Remote maintenance thanks to the EtherCAT interface
- ▶ Quick expert assistance in case of disturbances and shutdowns
- ▶ Supports predictive maintenance functions
- ▶ Reduced service and maintenance costs

### A VERY SECURE INVESTMENT

- ▶ Moderate procurement costs and low service and maintenance costs ensure a rapid return on investment

# EX-TRABEAM® ECO

## THE COST-EFFECTIVE STARTER MODEL



SMART CUTTING. BEST RESULTS.

## EX-TRABEAM® ECO

EX-TRABEAM® ECO laser cutting heads are particularly cost-effective entry-level solutions. They are ideal for all plant manufacturers that want to reap the benefits of the innovative cutting head concept without requiring particularly high cutting power.

### THE MAIN ADVANTAGES OF EX-TRABEAM® ECO:

- Laser power of up to 8 kW
- Motorized focus control
- Temperature-stable capacitive height sensor
- Embedded control system with an EtherCAT interface
- Monitoring of temperature and contamination of the main process window
- Compatible with ring-shaped laser beams and other laser beam shapes requiring high NA



#### OPTICAL SYSTEM

**MAGNIFICATION FOCUSING** 1.5 / 2.0  
**MAGNIFICATION COLLIMATION** 1.0  
**MAX. LASER POWER** 8 kW  
**WAVELENGTH** 1000–1100 NM  
**AXIAL FOCUS ADJUSTMENT RANGE TO CUTTING NOZZLE**  
 +5 / -15 MM @ M = 1.5 +15 / -30 MM @ M = 2.0  
**LATERAL FOCUS ADJUSTMENT RANGE TO CUTTING NOZZLE**  
 +/- 1

#### ELECTRICAL SYSTEM

**DC POWER SUPPLY** 24 V  
**MAX. CURRENT** 2 A  
**COMMUNICATION** EtherCAT  
**DISTANCE SENSOR MEASUREMENT RANGE** 0–20 MM  
**DISTANCE SENSOR MEASUREMENT FREQUENCY** 1.0 KHZ  
**DIGITAL DISTANCE SENSOR** EtherCAT  
**ANALOG DISTANCE SENSOR** 0–10 V

#### MECHANICAL SYSTEM

**SIZE** APPROX. 400 X 120 X 120 MM  
**WEIGHT** APPROX. 7.0 KG  
**LASER LIGHT CABLE STANDARD** QBH, LLK-D

#### COOLING SYSTEM

**COOLANT QUALITY** DI / DEMINERALIZED WATER  
**COOLANT TEMPERATURE** 20–40 °C (NON-CONDENSING)  
**COOLANT FLOW RATE** 1.0–2.0 L/MIN  
**MAX. COOLANT PRESSURE** 0.5 MPA  
**COOLANT CONNECTOR OD/ID** 6/4 MM

#### PNEUMATIC SYSTEM

**MAX. CUTTING GAS PRESSURE** 2.0 MPA  
**CUTTING GAS CONNECTOR OD/ID** 10 MM  
**MAX. CUTTING NOZZLE COOLING PRESSURE** 0.3 MPA  
**CUTTING NOZZLE COOLING CONNECTOR OD/ID** 4/3 MM

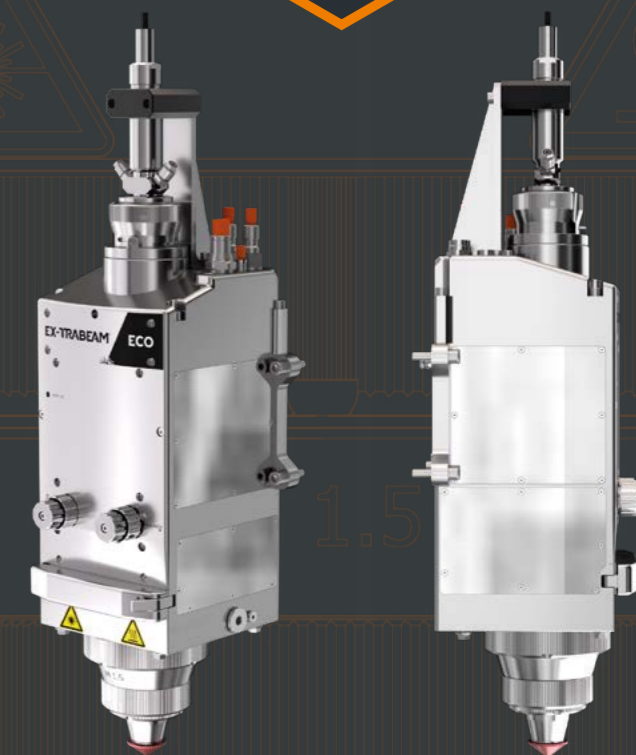
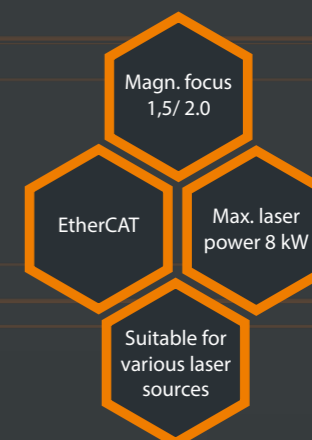

# EX-TRABEAM® HP

## THE SMART HOTSHOT



SMART CUTTING. BEST RESULTS.

## EX-TRABEAM® HP

EX-TRABEAM® HP cutting heads not only offer the same advantages as the EX-TRABEAM® ECO cutting heads but also monitor all optical components and cutting process signals, thus achieving maximum cutting precision and reliability as a fail-safe solution.

### THE MAIN ADVANTAGES OF EX-TRABEAM® HP:

- Piercing sensor
- Monitoring of all optical components and cutting process signals
- Ready for smart factories and Industry 4.0 applications
- Laser power of up to 8 kW
- Motorized focus control
- Temperature-stable capacitive height sensor
- Embedded control system with an EtherCAT interface
- Compatible with ring-shaped laser beams and other laser beam shapes requiring high NA



### OPTICAL SYSTEM

**MAGNIFICATION FOCUSING** 1.5 / 2.0  
**MAGNIFICATION COLLIMATION** 1.0  
**MAX. LASER POWER** 8 kW  
**WAVELENGTH** 1000–1100 NM  
**AXIAL FOCUS ADJUSTMENT RANGE TO CUTTING NOZZLE**  
 +5 / -15 MM @ M = 1.5    +15 / -30 MM @ M = 2.0  
**LATERAL FOCUS ADJUSTMENT RANGE TO CUTTING NOZZLE** +/- 1

Magn. focus  
1,5/ 2,0

EtherCAT

Max. laser  
power 8 kW

Suitable for  
various laser  
sources

### ELECTRICAL SYSTEM

**DC POWER SUPPLY** 24 V  
**MAX. CURRENT** 2 A  
**COMMUNICATION** EtherCAT  
**DISTANCE SENSOR MEASUREMENT RANGE** 0–20 MM  
**DISTANCE SENSOR MEASUREMENT FREQUENCY** 1.0 KHZ  
**DIGITAL DISTANCE SENSOR** EtherCAT  
**ANALOG DISTANCE SENSOR** 0–10 V

### MECHANICAL SYSTEM

**SIZE** APPROX. 400 X 120 X 120 MM  
**WEIGHT** APPROX. 7.0 KG  
**LASER LIGHT CABLE STANDARD** QBH, LLK-D

### COOLING SYSTEM

**COOLANT QUALITY** DI / DEMINERALIZED WATER  
**COOLANT TEMPERATURE** 20–40 °C (NON-CONDENSING)  
**COOLANT FLOW RATE** 1.0–2.0 L/MIN  
**MAX. COOLANT PRESSURE** 0.5 MPA  
**COOLANT CONNECTOR OD/ID** 6/4 MM

### PNEUMATIC SYSTEM

**MAX. CUTTING GAS PRESSURE** 2.0 MPA  
**CUTTING GAS CONNECTOR OD/ID** 10 MM  
**MAX. CUTTING NOZZLE COOLING PRESSURE** 0.3 MPA  
**CUTTING NOZZLE COOLING CONNECTOR OD/ID** 4/3 MM





# EX-TRABEAM® XP

## THE ROBUST POWERHOUSE



SMART CUTTING. BEST RESULTS.

## EX-TRABEAM® XP

As the next step up from the EX-TRABEAM® HP cutting heads in terms of technology, the EX-TRABEAM® XP cutting heads offer a significant increase in power up to 20 kW. The cooling system and all relevant components are tailored to manage this extra power.

### THE MAIN ADVANTAGES OF EX-TRABEAM® XP:

- Laser power of up to 20 kW, special cooling system for all critical components
- Available with an HLC-16 cable receiver for high-power laser sources
- Piercing sensor
- Monitoring of all optical components and cutting process signals
- Ready for smart factories and Industry 4.0 applications
- Motorized focus control
- Temperature-stable capacitive height sensor
- Embedded control system with an EtherCAT interface
- Compatible with ring-shaped laser beams and other laser beam shapes requiring high NA



### OPTICAL SYSTEM

**MAGNIFICATION FOCUSING** 1.5 / 2.0  
**MAGNIFICATION COLLIMATION** 1.0  
**MAX. LASER POWER** 20 kW  
**WAVELENGTH** 1000–1100 NM  
**AXIAL FOCUS ADJUSTMENT RANGE TO CUTTING NOZZLE**  
 +5 / -15 MM @ M = 1.5    +15 / -30 MM @ M = 2.0  
**LATERAL FOCUS ADJUSTMENT RANGE TO CUTTING NOZZLE** +/- 1

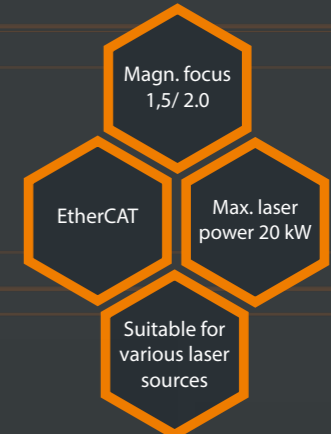

### ELECTRICAL SYSTEM

**DC POWER SUPPLY** 24 V  
**MAX. CURRENT** 2 A  
**COMMUNICATION** EtherCAT  
**DISTANCE SENSOR MEASUREMENT RANGE** 0–20 MM  
**DISTANCE SENSOR MEASUREMENT FREQUENCY** 1.0 KHZ  
**DIGITAL DISTANCE SENSOR** EtherCAT  
**ANALOG DISTANCE SENSOR** 0–10 V

### MECHANICAL SYSTEM

**SIZE** APPROX. 400 X 120 X 120 MM  
**WEIGHT** APPROX. 7.0 KG  
**LASER LIGHT CABLE STANDARD** QBH, LLK-D, HLC-16

### COOLING SYSTEM

**COOLANT QUALITY** DI / DEMINERALIZED WATER  
**COOLANT TEMPERATURE** 20–40 °C (NON-CONDENSING)  
**COOLANT FLOW RATE** 1.0–2.0 L/MIN  
**MAX. COOLANT PRESSURE** 0.5 MPA  
**COOLANT CONNECTOR OD/ID** 6/4 MM

### PNEUMATIC SYSTEM

**MAX. CUTTING GAS PRESSURE** 2.0 MPA  
**CUTTING GAS CONNECTOR OD/ID** 10 MM  
**MAX. CUTTING NOZZLE COOLING PRESSURE** 0.3 MPA  
**CUTTING NOZZLE COOLING CONNECTOR OD/ID** 4/3 MM

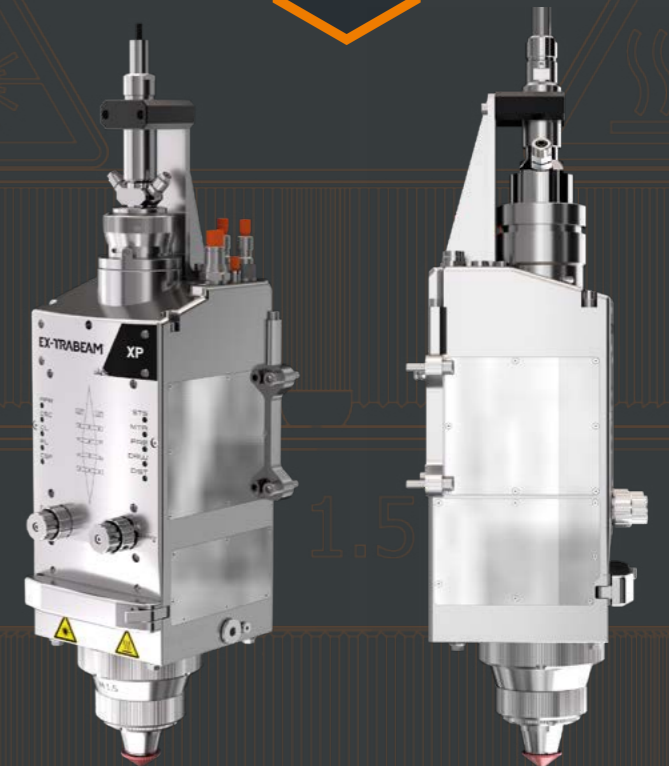

# EX-TRABEAM® ZOOM

## THE FLEXIBLE ALL-ROUNDER



SMART CUTTING. BEST RESULTS.

## EX-TRABEAM® ZOOM

With EX-TRABEAM® ZOOM laser cutting heads, both the focus position and focus diameter can be freely adjusted. Combined with a laser power of up to 20 kW, this makes them the ideal cutting heads for changing demands and high flexibility without having to forget any extra power.

### THE MAIN ADVANTAGES OF EX-TRABEAM® ZOOM:

- Zoom collimation system, free choice of magnification and focus position
- Laser power of up to 20 kW, special cooling system for all critical components
- Temperature-stable capacitive height sensor
- Piercing sensor
- Embedded control system with an EtherCAT interface
- Available with an HLC-16 cable receiver for high-power laser sources
- Monitoring of all optical components and cutting process signals
- Ready for smart factories and Industry 4.0 applications
- Compatible with ring-shaped laser beams and other laser beam shapes requiring high NA



#### OPTICAL SYSTEM

**MAGNIFICATION FOCUSING** 1.35 / 4.0  
**MAGNIFICATION COLLIMATION** 0.9–2.0  
**MAX. LASER POWER** 20 kW  
**WAVELENGTH** 1000–1100 NM  
**AXIAL FOCUS ADJUSTMENT RANGE TO CUTTING NOZZLE**  
 +5 / -15 MM @ M = 1.5    +15 / -30 MM @ M = 2.0  
**LATERAL FOCUS ADJUSTMENT RANGE TO CUTTING NOZZLE** +/- 1

#### ELECTRICAL SYSTEM

**DC POWER SUPPLY** 24 V  
**MAX. CURRENT** 4 A  
**COMMUNICATION** EtherCAT  
**DISTANCE SENSOR MEASUREMENT RANGE** 0–20 MM  
**DISTANCE SENSOR MEASUREMENT FREQUENCY** 1.0 KHZ  
**DIGITAL DISTANCE SENSOR** EtherCAT  
**ANALOG DISTANCE SENSOR** 0–10 V

#### MECHANICAL SYSTEM

**SIZE** APPROX. 620 X 161 X 157 MM  
**WEIGHT** APPROX. 11.0 KG  
**LASER LIGHT CABLE STANDARD** QBH, LLK-D, HLC-16

#### COOLING SYSTEM

**COOLANT QUALITY** DI / DEMINERALIZED WATER  
**COOLANT TEMPERATURE** 20–40 °C (NON-CONDENSING)  
**COOLANT FLOW RATE** 1.0–2.0 L/MIN  
**MAX. COOLANT PRESSURE** 0.5 MPA  
**COOLANT CONNECTOR OD/ID** 6/4 MM

#### PNEUMATIC SYSTEM

**MAX. CUTTING GAS PRESSURE** 2.0 MPA  
**CUTTING GAS CONNECTOR OD/ID** 10 MM  
**MAX. CUTTING NOZZLE COOLING PRESSURE** 0.3 MPA  
**CUTTING NOZZLE COOLING CONNECTOR OD/ID** 4/3 MM

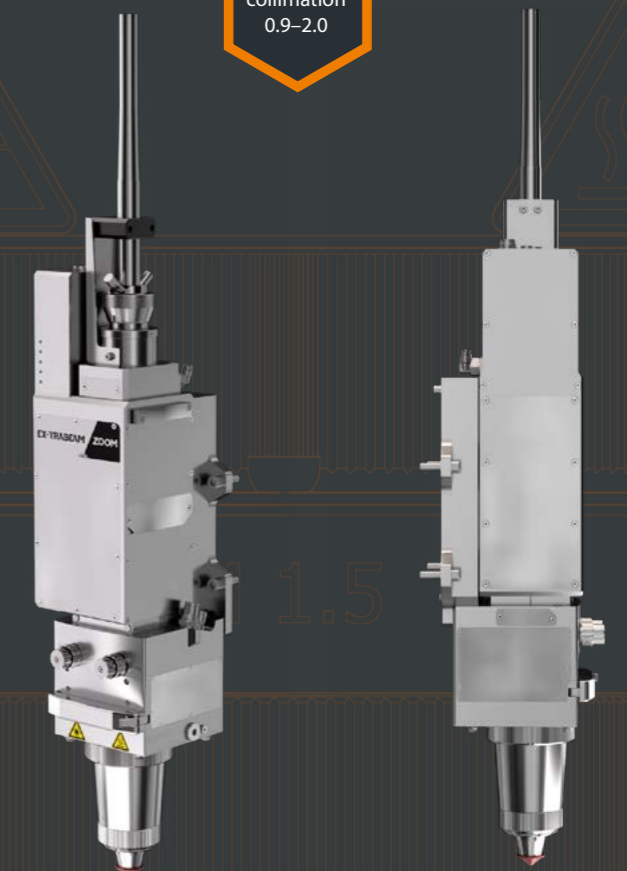

# THINK FRESH. CUT ORANGE.



**THERMACUT®** BRINGS FRESH IDEAS TO THE WORLD OF LASER CUTTING TECHNOLOGY. MAKE THE MOST OF THESE IDEAS AND REAP THE BENEFITS OF INNOVATIVE, RELIABLE, POWERFUL AND EXTREMELY EFFICIENT CUTTING SOLUTIONS

Discover our wide range of cutting solutions at [www.ex-trabeam.com](http://www.ex-trabeam.com)

**A GLOBAL PROVIDER OF ENHANCED THERMAL CUTTING SOLUTIONS**

THERMACUT®, THE CUTTING COMPANY®, FHT-EX®, EX-TRAFIRE®, EX-TRACK®, EX-TRABEAM® AND EX-TRAFROME® ARE REGISTERED TRADEMARKS OF THERMACUT, K.S. AND MAY BE REGISTERED IN CZECH REPUBLIC AND/OR OTHER COUNTRIES. ALL OTHER TRADEMARKS ARE PROPERTIES OF THEIR RESPECTIVE OWNERS.

**THERMACUT®**  
THE CUTTING COMPANY®

[WWW.THERMACUT.COM](http://WWW.THERMACUT.COM)  
TEL. +420 556 423 440  
SALES@THERMACUT.CZ